

Gegenring Type B

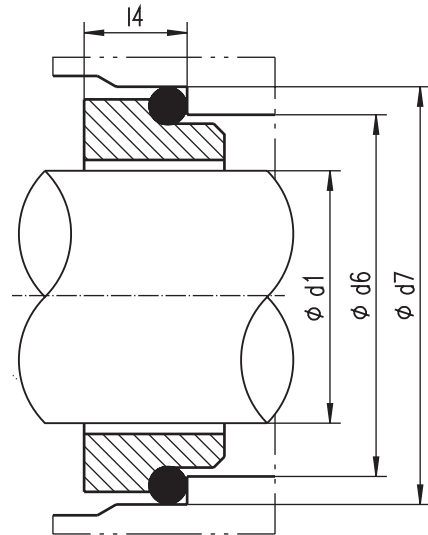

Werkstoffe		
Gegenring:	SIC	(U32)
	Kohle	(Z32)
	Chromguss	(Y1)
	Edelstahl	(E)
Elastomer:	Viton	(V)
	EPDM	(D)
	FEP	(V2)

d ₁	d ₆	d ₇	l ₄
10	15,5	19,2	6,6
12	17,5	21,6	5,6
14	20,5	24,6	5,6
15	20,5	24,6	6,6
16	22,0	28,0	7,5
18	24,0	30,0	8,0
20	29,5	35,0	7,5
22	29,5	35,0	7,5
24	32,0	38,0	7,5
25	32,0	38,0	7,5
28	36,0	42,0	9,0
30	39,2	45,0	10,5
32	42,2	48,0	10,5
33	44,2	50,0	11,0
35	46,2	52,0	11,0
38	49,2	55,0	10,3
40	52,2	58,0	10,8
43	53,3	62,0	12,0
45	55,3	64,0	11,6
48	59,7	68,4	11,6
50	60,8	69,3	11,6
53	63,8	72,3	12,3
55	66,5	75,4	13,3
58	69,5	78,4	13,3
60	71,5	80,4	13,3
65	76,5	85,4	13,0
68	82,7	91,5	13,7
70	83,0	92,0	13,0
75	90,2	99,0	14,0
80	95,2	104,0	15,0
85	100,2	109,0	15,0
90	105,2	114,0	15,0
95	111,6	120,3	16,0
100	114,5	123,3	16,0

Stand 06/07

Änderungen jederzeit vorbehalten



Robert-Bosch-Str. 12
49134 Wallenhorst

Tel.: 05407/81740
Fax: 05407/817420

fluiten@fluiten.de
www.fluiten.de