

Gegenring Type A8

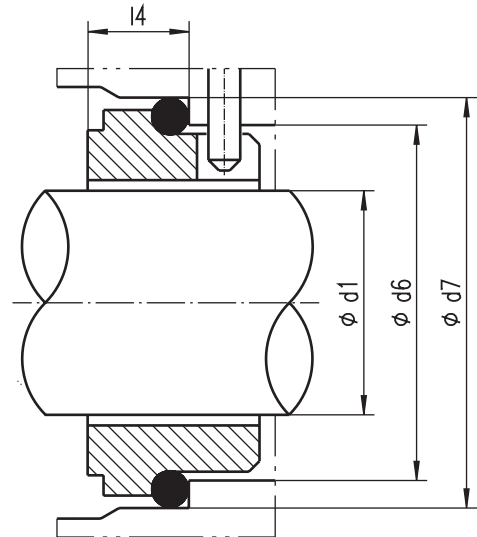

Werkstoffe

Gegenring:	SIC	(U31)
	Kohle	(Z31)
	Hartmetall	(K21)
	Chromguss	(Y1)
	Keramik	(C)
	Edelstahl	(E)
Elastomer:	Viton	(V)
	EPDM	(D)
	PTFE	(T)

d ₁ Metrisch	d ₁ Zoll	d ₆	d ₇	l ₄
	15,88	24,31	28,57	9,00
	19,05	27,48	31,75	9,00
20		29,06	33,32	9,00
	22,23	30,66	34,93	9,00
25		33,84	39,85	10,00
	25,40	33,84	39,85	10,00
28		37,01	43,05	10,00
30		38,61	44,63	10,00
32	31,75	40,28	46,32	10,00
35	34,93	43,46	49,48	10,00
38	38,10	46,63	52,56	10,00
40		48,13	54,25	10,00
42	41,28	49,81	55,83	10,00
45	44,45	52,98	59,02	10,00
48	47,63	57,66	63,68	10,00
50		59,33	65,37	10,00
	50,80	60,83	66,85	10,00
55	53,98	64,01	70,03	10,00
	57,15	67,18	73,20	10,00
58		68,86	79,50	10,00
60		70,36	76,38	10,00
	60,33	70,36	76,38	10,00
	63,50	73,53	79,56	10,00
65		75,21	81,23	10,00
	66,68	76,71	82,73	10,00
70	69,85	79,88	85,90	10,00
73	73,03	83,06	89,08	10,00
75		84,73	90,77	10,00
	76,20	89,41	95,43	10,00
80		94,26	100,29	10,00
	82,55	95,76	101,78	10,00
85		98,93	104,77	10,00
	88,90	102,11	108,13	10,00
90		103,78	109,82	10,00
95		108,46	114,30	10,00
100		113,31	119,33	10,00
	101,60	117,98	124,00	10,00
105	104,78	121,16	127,00	10,00
100		126,01	131,77	10,00
115	114,30	130,68	136,52	10,00
120		137,03	142,87	10,00

Stand 08/08

Änderungen jederzeit vorbehalten



Robert-Bosch-Str. 12
49134 Wallenhorst

Tel.: 05407/81740
Fax: 05407/817420

fluiten@fluiten.de
www.fluiten.de